

CFG4 100W 伺服電機

單軸/1-axis

▶ 軌道內嵌
Built-in Guideway

▶ 螺桿驅動
Ball Screw Drive

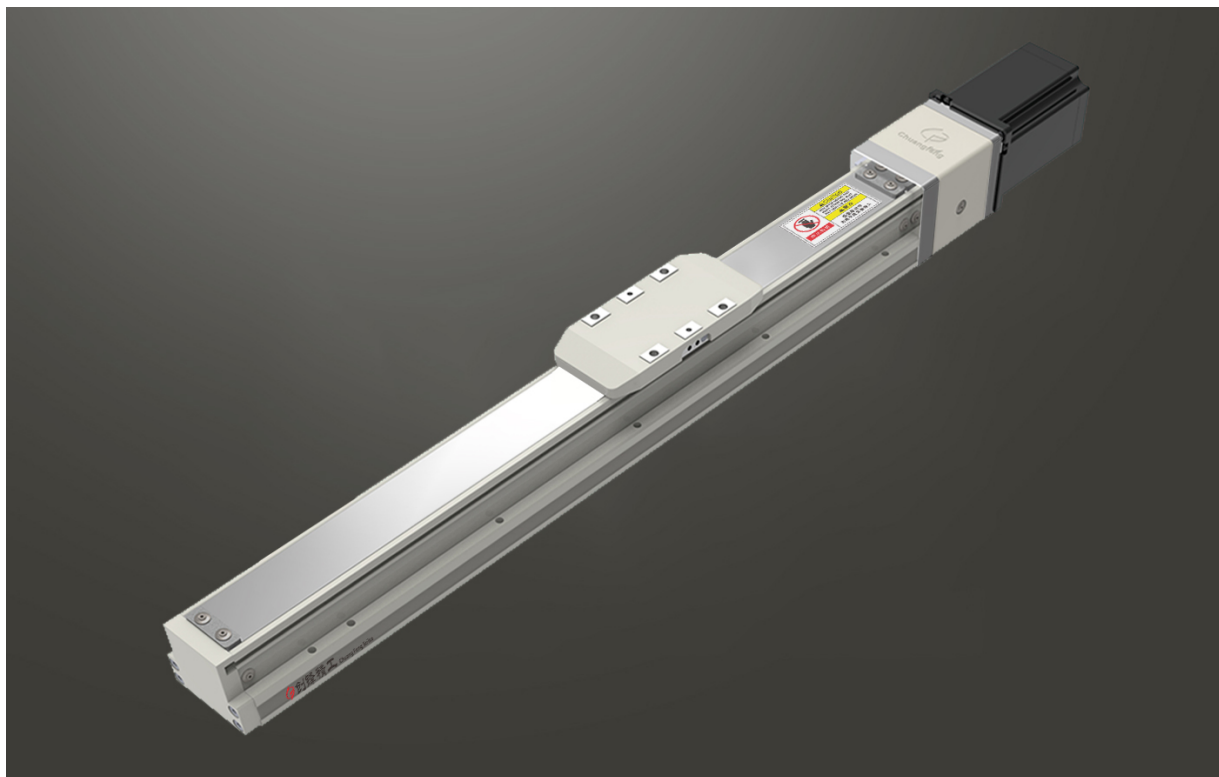

此圖僅供參考，出貨規格詳見尺寸圖面
The picture is just for the reference. Please check the the actual dimensions on the drawing.

最大行程
Maximum Stroke **800mm**

最高速度
Maximum Speed **500mm/s**

馬達容量
Motor Output **100W**

滾珠螺桿
Ball Screw **Ø10mm**

型號表示方式 Ordering Method

CFG4 - L 2 - 100 - BC - T100W - C 4 - MB-3M

本體型號
Model

螺桿導程
Ball Screw Lead

行程
Stroke

02	02mm	50-800mm
05	05mm	50間隔 50 mm Pitch
10	10mm	

馬達位置
Motor Position

BC	馬達外露 Motor Exposed
BM	馬達下折 Motor Bottom Side
BL	馬達左折 Motor Left Side
BR	馬達右折 Motor Right Side

電機安裝標準
Motor installation

T	通用馬達安裝標準: 三菱 Mitsubishi
	台達 Delta
	安川 Yaskawa
	匯川 Inovance
	等等 Etc
P	松下馬達安裝標準

馬達容量
Motor Output

100W	100W
200W	-
400W	-
750W	-

原點感應器
Home Sensor

	外掛型 Out Side
C	馬達側 Motor Side
D	反馬達側 Opposite Motor Side
	無 SENSOR No Sensor
E	無 SENSOR No Sensor

※選擇行程50時，有以下限制：
When the stroke is 50mm, the sensor installation has the following restrictions:
1. 原點與極限需放置於不同側。
Home sensor and limit sensor has to be installed on the different side of body.
2. 滑座左右兩側皆需安裝感應片。
Both sides of slider need to install the sensor trigger device.

端點極限感應器
Limit Sensor

	外掛型 Out Side
3	1只 1 Pc
4	2只 2 Pc
	無 SENSOR No Sensor
5	無 SENSOR No Sensor

馬達廠牌
Motor Brand

MB-3M	含電機，廠家安裝三菱帶利車電機，線長3米
ZMB	不含電機，客戶自己安裝三菱帶利車電機
KMB	不含電機，客戶提供三菱帶利車電機，廠家安裝

※若無煞車則B不表示。
※If No Brake, No B Description.

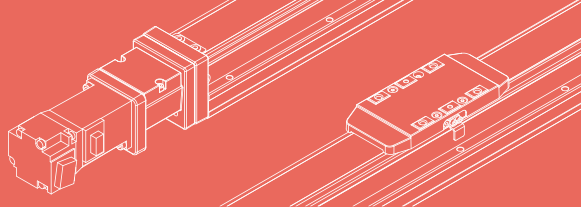

免費服務專線：大陸 400-716-8787
Toll-free Number China

基本仕様 Specification

規格 Spec	位置重複精度 Repeatability (mm)	±0.01			
	螺桿導程 Ball Screw Lead (mm)	2	5	10	
	最高速度 Maximum Speed (mm/s)	100	250	500	
	最大可搬重量 Maximum Payload	水平使用 Horizontal (kg)	25	20	12
		垂直使用 Vertical (kg)	8	8	3.5
	定額推力 Rated Thrust (N)	854	285	142	
標準行程 Stroke Pitch (mm)	50-800mm/50間隔 50 mm Pitch				
部品 Parts	AC伺服馬達容量 AC Servo Motor Output (W)	100			
	滾珠螺桿外徑 Ball Screw Ø (mm)	C7 φ 10			
	連軸器 Coupling (mm)	7X8			
	原點感應器 Home Sensor	外掛 Outside	EE-SX674(NPN) FC-SPX307Z-2M(NPN)		

感應器接線圖<原點及端點> Sensor Layout

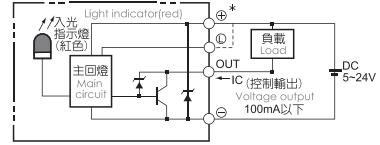

*行程超過500時，會產生螺桿崩磨，此時請將速度調降。
When the stroke is over 500mm, the run-out of the ball screw will occur.
We recommend to low down the working speed under this circumstances.
*馬達加減速設定0.2秒。
Acceleration and deceleration value is set 0.2 second.

容許負載力距表 Allowable Overhang

水平安裝 Horizontal Installation				壁掛安裝 Wall Installation				垂直安裝 Vertical Installation				
(單位 Unit : mm)				(單位 Unit : mm)				(單位 Unit : mm)				
導程 2 Lead	12kg	1000	55	80	12kg	80	55	1000	導程 2 Lead	4kg	195	195
	18kg	750	35	50	18kg	50	35	750		8kg	100	100
	25kg	500	23	32	25kg	32	23	500		-	-	-
導程 5 Lead	10kg	550	53	70	10kg	72	52	550	導程 5 Lead	4kg	150	150
	15kg	350	32	45	15kg	45	32	345		8kg	75	75
	20kg	250	22	31	20kg	31	22	250		-	-	-
導程 10 Lead	8kg	305	59	75	8kg	75	59	300	導程 10 Lead	2kg	260	260
	10kg	240	45	57	10kg	58	45	240		3.5kg	150	150
	12kg	195	37	47	12kg	47	37	190		-	-	-

靜態容許負載慣量 Static Loading Moment

靜態容許負載慣量 Static Loading Moment		(單位 Unit : N.m)
MY		79
MP		79
MR		116

*力距表所表示的數據，代表重心。
The torque value in the chart indicate the center of gravity.
*符合型錄規範的正常使用下，保證壽命為10000公里。
Operation life is 10,000km when the product is using under the specified conditions.
*倒吊使用無法套用標準規範，如有需求請洽詢我司業務。
Data information is not for ceiling-mount inverse use.
Contact us for the details if you want to apply ceiling-mount inverse usage.

搭配步進馬達一覽表 Options of Stepper Motors

廠牌 Brand	馬達記號 Mark	煞車有無 Brake	馬達容量 Watt	電源電壓 AC-Voltage	伺服馬達型號 Motor Model	驅動器型號 Driver Model
三菱 Mitsubishi	M	無煞車(水平仕様) No Brake (Horizontal Type)	100	220	HG-KN13J-S100	MR-JE-10A
		有煞車(垂直仕様) With Brake (Vertical Type)	100	220	HG-KN13BJ-S100	MR-JE-10A
松下 Panasonic	P	無煞車(水平仕様) No Brake (Horizontal Type)	100	220	MSMF012L1U2M	MADLN05SE
		有煞車(垂直仕様) With Brake (Vertical Type)	100	220	MSMF012L1V2M	MADLN05SE
台達 Delta	T	無煞車(水平仕様) No Brake (Horizontal Type)	100	220	ECM-B3L-C20401RS1	ASD-B3-0121-L
		有煞車(垂直仕様) With Brake (Vertical Type)	100	220	ECM-B3L-C20401SS1	ASD-B3-0121-L

應用例
Application
一般/內嵌式樣
CFG/CFV
無塵/皮帶式樣
CFA/CFB
一般/螺桿式樣
CFK
齒輪齒條式樣
CFM
一般/螺桿式樣
CFS
一般/皮帶式樣
CFT
無塵/螺桿式樣
CFF
無塵/皮帶式樣
CFE
直交連結
XYG/XYS/YVT
Reference

單軸
1axis
CFG

CFG4
CFG5
CFG8
CFG12
CFG15
CFG5S
CFG8S

馬達外露/馬達下折

Motor Exposed / Motor Bottom Side

BC 馬達外露 Motor Exposed



• CAD圖面可至 www.cf16.com 下載 •

單位 Unit: mm

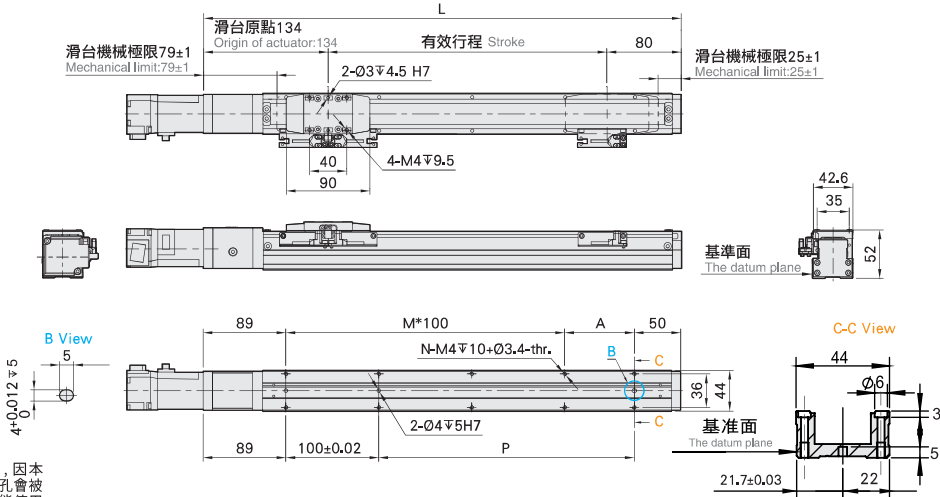

※行程 50 時，因本體上鎖式固定孔會被滑座遮住，僅能使用 4 支螺絲固定，建議客戶本體使用下鎖式固定孔鎖附。

When the stroke is 50mm, if fixing the body from the top to the bottom, the fixing hole will be blocked by slider and only can be uses 4 screws to fix as a result, suggest that fixing actuator body from the bottom to the top.

有效行程 Stroke	50*	100	150	200	250	300	350	400	450	500	550	600	650	700	750	800
L	264	314	364	414	464	514	564	614	664	714	764	814	864	914	964	1014
A	25	75	25	75	25	75	25	75	25	75	25	75	25	75	25	75
M	1	1	2	2	3	3	4	4	5	5	6	6	7	7	8	8
N	6	6	8	8	10	10	12	12	14	14	16	16	18	18	20	20
P	25	75	125	175	225	275	325	375	425	475	525	575	625	675	725	775
KG	0.95	1.12	1.29	1.47	1.65	1.83	2.01	2.19	2.37	2.55	2.73	2.91	3.09	3.27	3.45	3.63

BM 馬達下折 Motor Bottom Side



• CAD圖面可至 www.cf16.com 下載 •

單位 Unit: mm

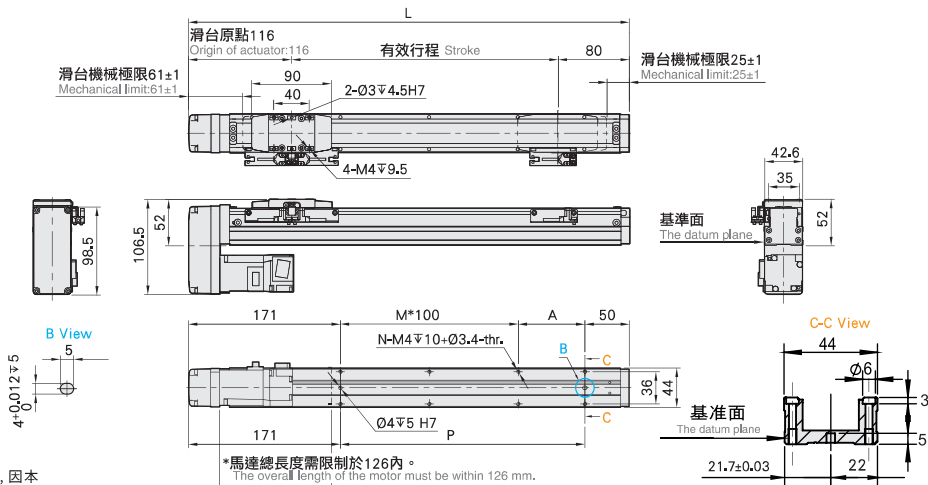

※行程 50 時，因本體上鎖式固定孔會被滑座遮住，僅能使用 4 支螺絲固定，建議客戶本體使用下鎖式固定孔鎖附。

When the stroke is 50mm, if fixing the body from the top to the bottom, the fixing hole will be blocked by slider and only can be uses 4 screws to fix as a result, suggest that fixing actuator body from the bottom to the top.

有效行程 Stroke	50*	100	150	200	250	300	350	400	450	500	550	600	650	700	750	800
L	246	296	346	396	446	496	546	596	646	696	746	796	846	896	946	996
A	25	75	25	75	25	75	25	75	25	75	25	75	25	75	25	75
M	0	0	1	1	2	2	3	3	4	4	5	5	6	6	7	7
N	4	4	6	6	8	8	10	10	12	12	14	14	16	16	18	18
P	25	75	125	175	225	275	325	375	425	475	525	575	625	675	725	775
KG	1.04	1.22	1.40	1.58	1.76	1.94	2.12	2.30	2.48	2.66	2.84	3.02	3.20	3.38	3.56	3.74

*馬達下折時，若選用煞車馬達，或是超出馬達總長度限制時無法套用標準 PIN 孔，如有需求請洽我司業務。

When motor with brake assembled on lower side, or the total length over than spec limit, it may not use standard pinhole. Please contact our sales department if you need more information & requirement.

馬達左折/馬達右折

Motor Left Side / Motor Right Side

BL 馬達左折 Motor Left Side



• CAD圖面可至 www.cf16.com 下載 •

單位 Unit : mm

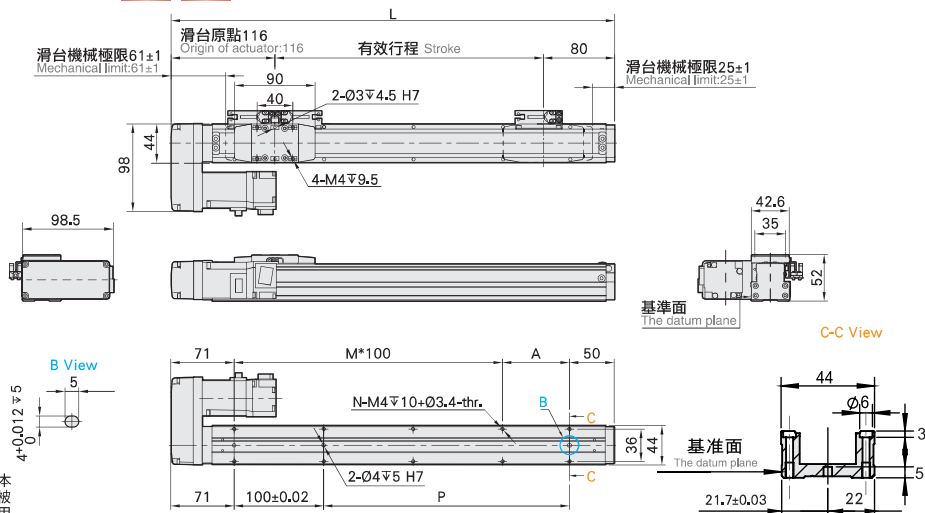

※行程 50 時，因本體上鎖式固定孔會被滑座遮住，僅能使用 4 支螺絲固定，建議客戶本體使用下鎖式固定孔鎖附。

When the stroke is 50mm, if fixing the body from the top to the bottom, the fixing hole will be blocked by slider and only can be uses 4 screws to fix as a result, suggest that fixing actuator body from the bottom to the top.

有效行程 Stroke	50*	100	150	200	250	300	350	400	450	500	550	600	650	700	750	800
L	246	296	346	396	446	496	546	596	646	696	746	796	846	896	946	996
A	25	75	25	75	25	75	25	75	25	75	25	75	25	75	25	75
M	1	1	2	2	3	3	4	4	5	5	6	6	7	7	8	8
N	6	6	8	8	10	10	12	12	14	14	16	16	18	18	20	20
P	25	75	125	175	225	275	325	375	425	475	525	575	625	675	725	775
KG	1,04	1,22	1,40	1,58	1,76	1,94	2,12	2,30	2,48	2,66	2,84	3,02	3,20	3,38	3,56	3,74

BR 馬達右折 Motor Right Side



• CAD圖面可至 www.cf16.com 下載 •

單位 Unit : mm

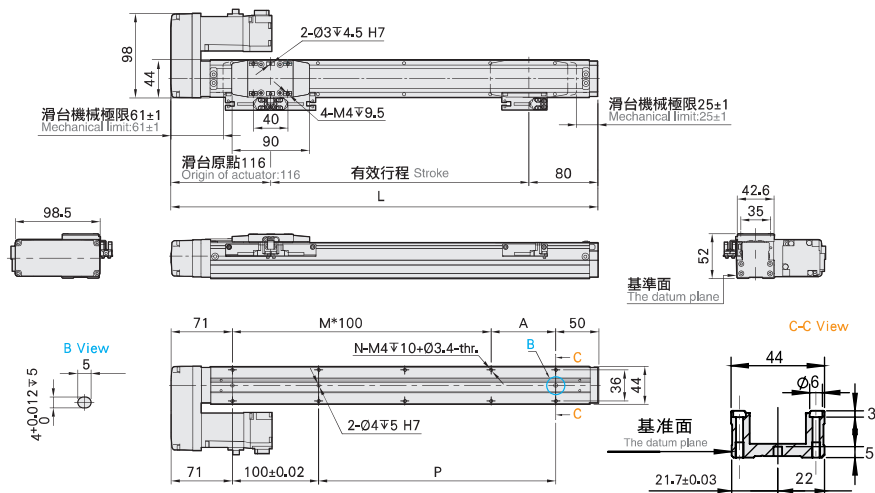

※行程 50 時，因本體上鎖式固定孔會被滑座遮住，僅能使用 4 支螺絲固定，建議客戶本體使用下鎖式固定孔鎖附。

When the stroke is 50mm, if fixing the body from the top to the bottom, the fixing hole will be blocked by slider and only can be uses 4 screws to fix as a result, suggest that fixing actuator body from the bottom to the top.

有效行程 Stroke	50*	100	150	200	250	300	350	400	450	500	550	600	650	700	750	800
L	246	296	346	396	446	496	546	596	646	696	746	796	846	896	946	996
A	25	75	25	75	25	75	25	75	25	75	25	75	25	75	25	75
M	1	1	2	2	3	3	4	4	5	5	6	6	7	7	8	8
N	6	6	8	8	10	10	12	12	14	14	16	16	18	18	20	20
P	25	75	125	175	225	275	325	375	425	475	525	575	625	675	725	775
KG	1,04	1,22	1,40	1,58	1,76	1,94	2,12	2,30	2,48	2,66	2,84	3,02	3,20	3,38	3,56	3,74